



# ASSEMBLY INSTRUCTIONS

## Signature Series

### 16K 5<sup>TH</sup> WHEEL HITCH

**DEALER/INSTALLER:**

(1) Provide this Manual to end user.

**END USER:**

- (1) Read and follow this Manual every time you use Hitch.
- (2) Save this Manual for future reference.
- (3) Pass on copies of Manual to any other user or owner of Hitch.

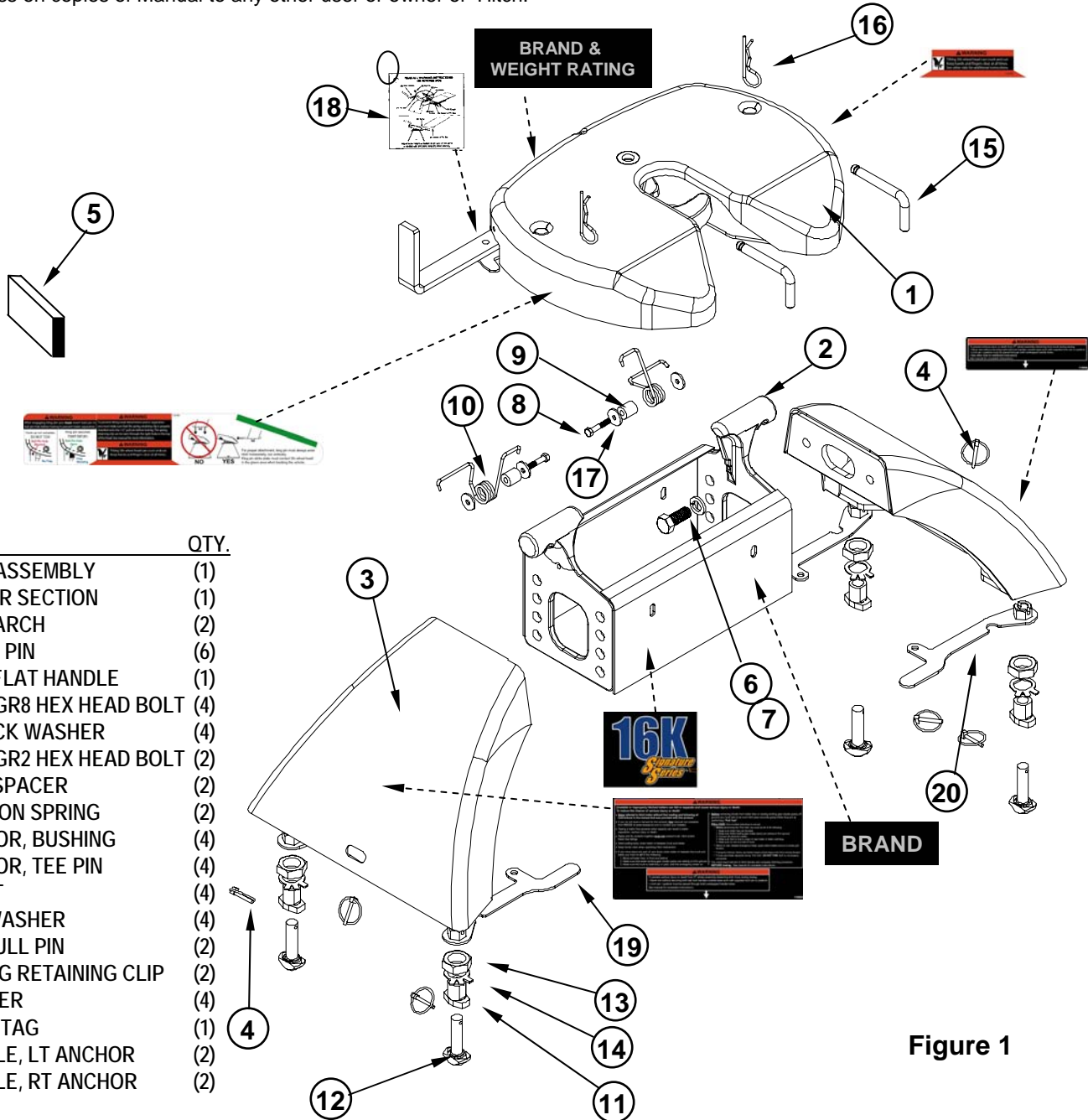


Figure 1

PART	QTY.
1. HEAD ASSEMBLY	(1)
2. CENTER SECTION	(1)
3. BASE ARCH	(2)
4. LYNCH PIN	(6)
5. GRIP, FLAT HANDLE	(1)
6. 5/8-11 GR8 HEX HEAD BOLT	(4)
7. 5/8 LOCK WASHER	(4)
8. 1/4-20 GR2 HEX HEAD BOLT	(2)
9. TUBE SPACER	(2)
10. TORSION SPRING	(2)
11. ANCHOR, BUSHING	(4)
12. ANCHOR, TEE PIN	(4)
13. 1" NUT	(4)
14. TAB WASHER	(4)
15. 1/2" PULL PIN	(2)
16. SPRING RETAINING CLIP	(2)
17. WASHER	(4)
18. HANG TAG	(1)
19. HANDLE, LT ANCHOR	(2)
20. HANDLE, RT ANCHOR	(2)

**For Installation Assistance or Technical Help, Call 1-800-758-0869**

**⚠ WARNING:**

**Failure to follow all of these instructions may result in death or serious injury!**

**INDEX**

1. GUIDELINES FOR MATCHING TOW VEHICLE AND TRAILER	P. 2-4
2. ASSEMBLY INSTRUCTIONS	P. 5-10
3. CEQUENT TOWING PRODUCTS SEVEN YEAR LIMITED WARRANTY	P. 11

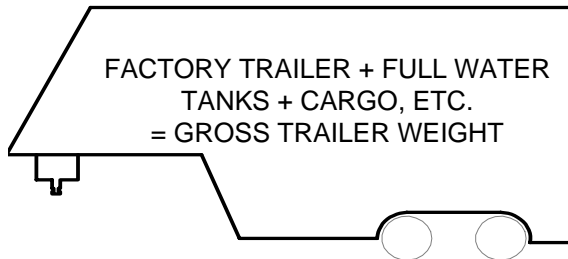
**GUIDELINES FOR MATCHING HITCH, TRUCK, AND TRAILER**

**⚠ WARNING:**

**Failure to check and follow tow ratings could result in tow vehicle damage or truck and trailer separation while towing.**

- Trailer and its contents together must not exceed truck, hitch and/or trailer tow ratings.
- Towing vehicle must have a manufacturer’s rated towing capacity equal to or greater than the gross trailer weight (dry weight of the trailer plus payload of the trailer). (Figure 2)
- Gross weight of trailer must not exceed 16,000 pounds.
- King pin weight must not exceed 4,000 pounds (Figure 3). If in doubt have king pin weight measured by qualified facility.

Figure 2



1. Check Tow Ratings:

Vehicle Tow Rating: \_\_\_\_\_  
 Signature Series Hitch Rating: 16,000 lbs.  
 Gross Trailer Weight (Figure 2): \_\_\_\_\_

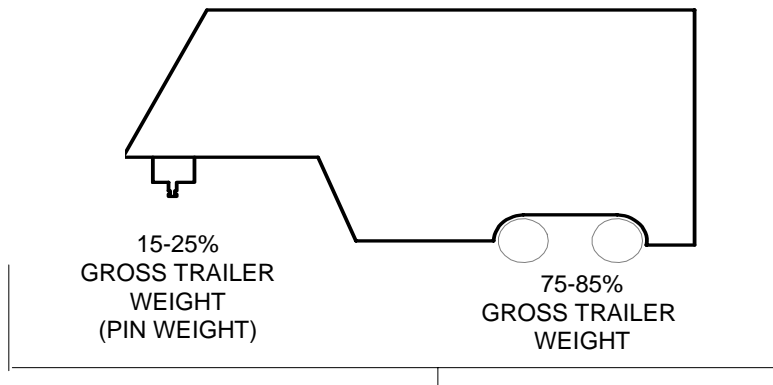
**\*Trailer weight should be the lowest of these recorded ratings for safe towing conditions.**

2. **Cequent Towing Products** hitches are designed for use with recreational fifth wheel trailers only. Hitch applications other than recreational fifth wheel trailers must be approved in writing by **Cequent Towing Products**’ Engineering Department.

3. Use only a SAE 2-inch kingpin with your *Signature Series* Fifth Wheel Hitch.

4. Approximately 15%-25% of trailer weight should be on hitch (Pin Weight). See Figure 3.

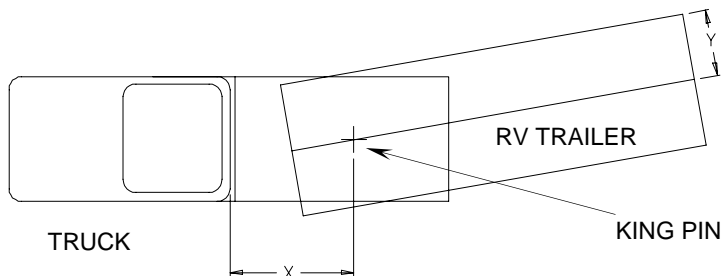
Figure 3



5. Trucks come in many different configurations. **Cequent Towing Products'** hitches are designed for use in light trucks such as the Ford F-Series, the Chevy Silverado and the Dodge Ram. **Cequent Towing Products** recommends the use of long bed (8ft) light trucks for the best combination in truck - trailer turning clearance.

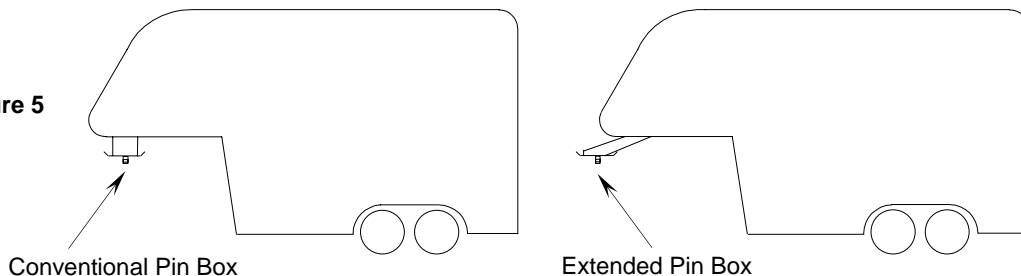
Rule of thumb: The distance from the back of the truck cab to the center of the rear truck axle ("X" in Figure 4), should be approximately 4 inches greater than one-half the trailer width ("Y" in Figure 4)

**Figure 4**



6. If a short bed pickup (less than 8 ft. but longer than 6 ft.) is to be used for towing, **Cequent Towing Products** recommends the trailer be equipped with an extended pin box to help gain additional truck - trailer turning clearance (See trailer manufacturer for options) (Figure 5). It also may be helpful to add a *Signature Series* Slider (**Part # 30070 / 40270**) for increased turning clearance for low speed, non-highway maneuvering.

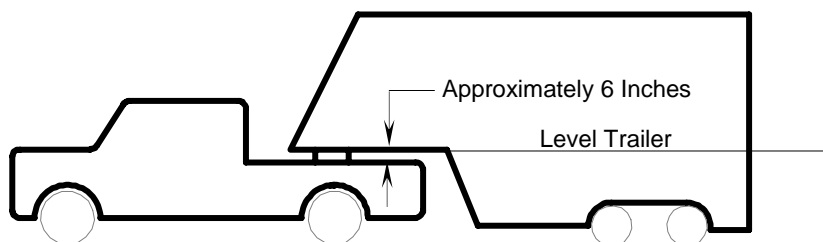
**Figure 5**



**⚠ WARNING:**  
**Do Not install this fifth wheel hitch on or attempt to tow with a short bed pickup truck that has a bed shorter than 6 ft.!**

7. The height of the hitch and the pin box should be adjusted so the trailer is approximately level as it is towed. Allow approximately 6 inches clearance between the top of the pickup walls and the underside of the front of the trailer for pitch and roll of the trailer. (Figure 6). Allow more clearance between pickup walls and trailer for off road use.

**Figure 6**



**CAUTION:**  
 The measurements above are guidelines. If your measurements are close to these numbers re-check clearances. If vehicle and/or trailer has any added bed vicinity accessories (i.e. fairings, air dams, ground effects, bed rails, etc.). Additional dimensioning and clearance checks have to be made.

8. Hitch height determination:  
 With trailer leveled and on level ground measure from the ground to the king pin box, "A" in Figure 7. Secondly measure from the height of the inside of the truck bed, "B" in Figure 7. Dimensions "C" and "D" in Figure 7 can be used to determine the amount of clearance over the side rails, as mentioned in Note 7.

$$\text{Hitch Height} = A - B + 2''$$

The 2" value is an estimate of suspension compression due to king pin weight of the trailer. This compression could range between 1"-5" depending on the truck being used and the trailer being towed.

$$D - C + 2'' > 6'' \text{ as noted in Note 7.}$$

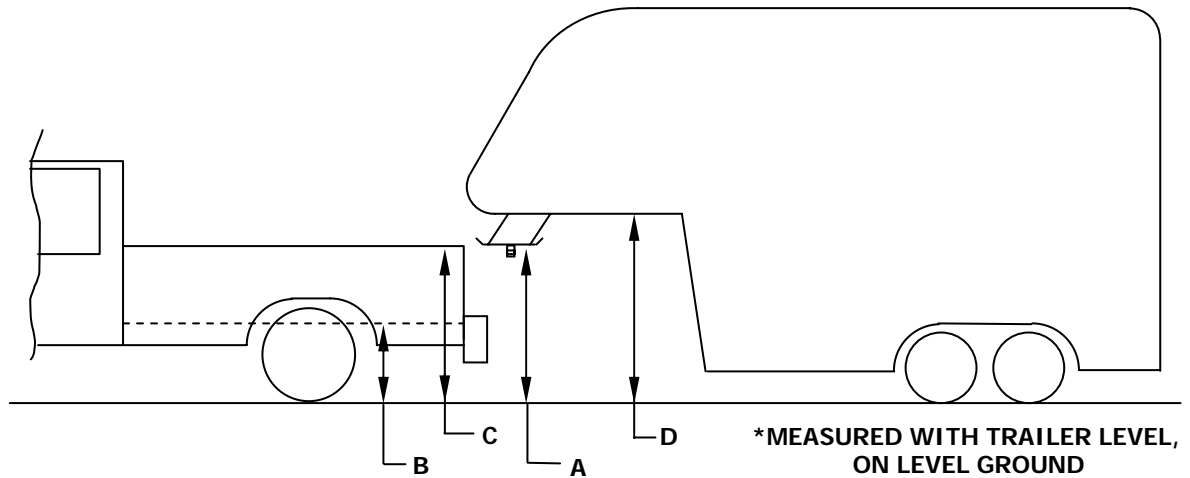


Figure 7

9. If a lube plate is to be used with a *Signature Series* 5<sup>th</sup> Wheel it must be at least 12" in diameter. **Cequent Towing Products** offers this optional lube plate as part # 83001 / 40001.

**⚠ WARNING:**

- Connection for trailer wiring must be located at the side of the truck bed between the driver's seat and the rear wheel to prevent operators from working between the truck and trailer.
- Avoid putting any part of your body under the trailer or between the truck and trailer. Unexpected or accidental movement of the truck or the trailer can cause serious injury or death
- If you must place any part of your body under the trailer or between the truck and trailer you **MUST** perform **ALL** of the following steps:
  - Check that the truck transmission is in park
  - Check that the emergency brake is on
  - Block in front of and behind all trailer tires
  - Check that the trailer landing gear are resting on firm ground

**SIGNATURE SERIES FIFTH WHEEL ASSEMBLY**

**TOOLS**

- 7/16", 9/16" and 15/16" Socket & Open End Wrench
- 200 lb-ft Torque Wrench
- 1-1/2" Box End Wrench

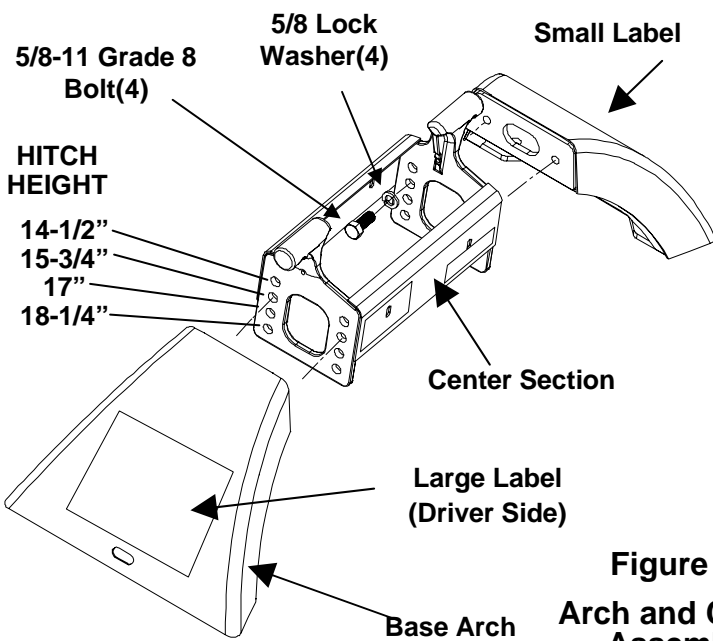
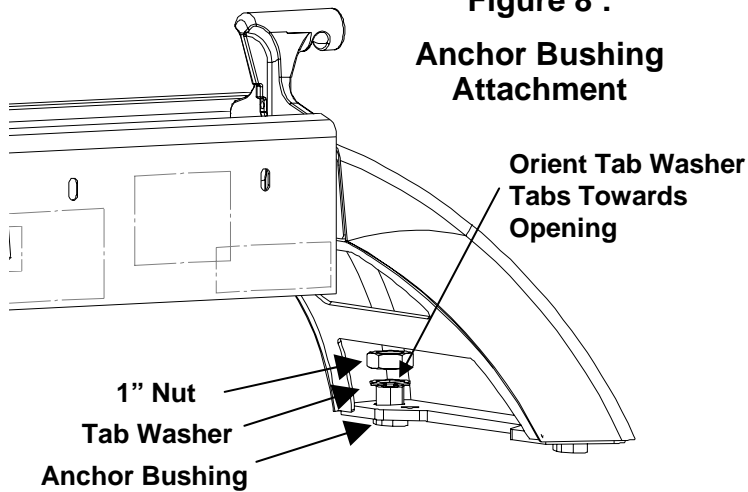
1. Check both boxes for all components listed in **Figure 1** and become familiar with component terminology. Anchor assemblies may be packed partially assembled and will need to be disassembled for installation.
2. Loosely assemble the four anchor bushings, less the anchor tee pins and handles, to the base arches using the tab washer and 1" nut (Note: Be sure to place tab washer in order for tabs to face opening) (see **Figure 8**); and the two base arches to the center section using 5/8-11 hex head bolts and lock washers (see **Figure 9**).

NOTE A : Hole positions used in assembly will need to be chosen based on the head height measurements taken previously. Choose calculated height closest to one of the following height dimensions: 14-1/2"(top holes), 15-3/4"(2<sup>nd</sup> holes down), 17"(3<sup>rd</sup> holes down), 18-1/4"(bottom holes).

NOTE B : The fore/aft position of the head relative to the tow vehicle axle can be adjusted by 1-1/2" based on the position of the center section (see **Figure 10**). Choose the position that most closely positions the king pin 2" ahead of tow vehicle axle center and allows for proper towing clearances. See Chart 1 below for suggested Center Section offset position on your vehicle.

NOTE C : Base arch with the larger label must be positioned on the Driver's side of the vehicle.

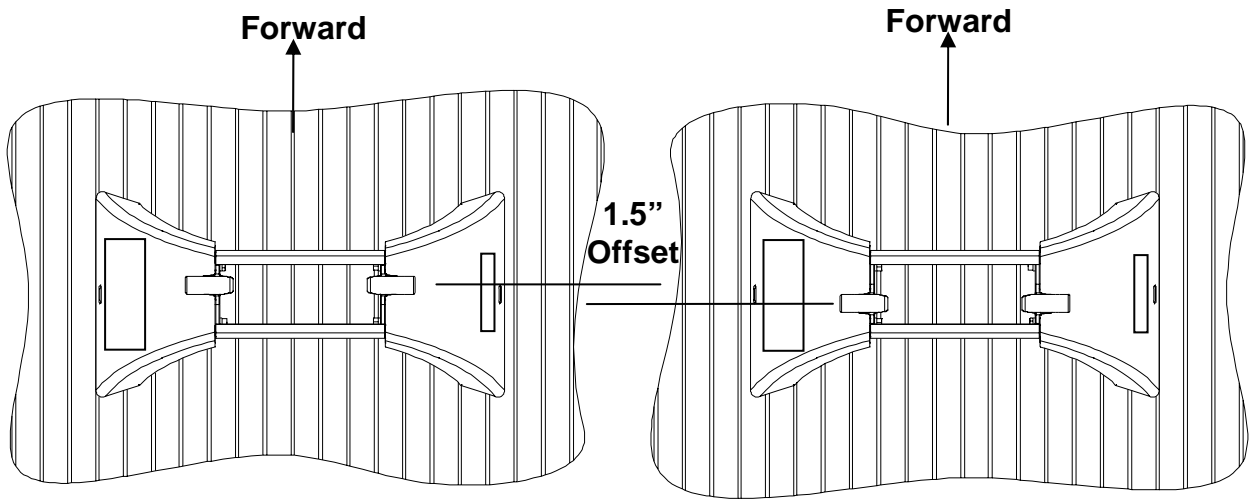
**Figure 8 :  
Anchor Bushing  
Attachment**



**Figure 9 :  
Arch and Center  
Assembly**

Year	Vehicle Fit	Center-Section Offset
1999-2004	GM 1500/2500 Series 8' Bed	Rearward
1999-2004	GM 1500/2500 Series 6' Bed	Forward
2001-2004	GM 3500 All	Forward
1988-2000	GM C/K Series 8' Bed Old Body Style	Forward
1988-2000	GM C/K Series 6' Bed Old Body Style	Rearward
2004	Ford F-150 New Body Style, 6' & 8' Bed	Forward
2004	Ford F-150 Heritage All	Forward
1999-2004	Ford F-250/F-350 Super Duty, All	Rearward
2002-2004	Dodge Ram 1500 All	Forward
2002-2004	Dodge Ram 2500/3500 Heavy Duty, All	Forward
1994-2001	Dodge Ram All	Forward

**Chart 1 : Suggested Center Section Offset**

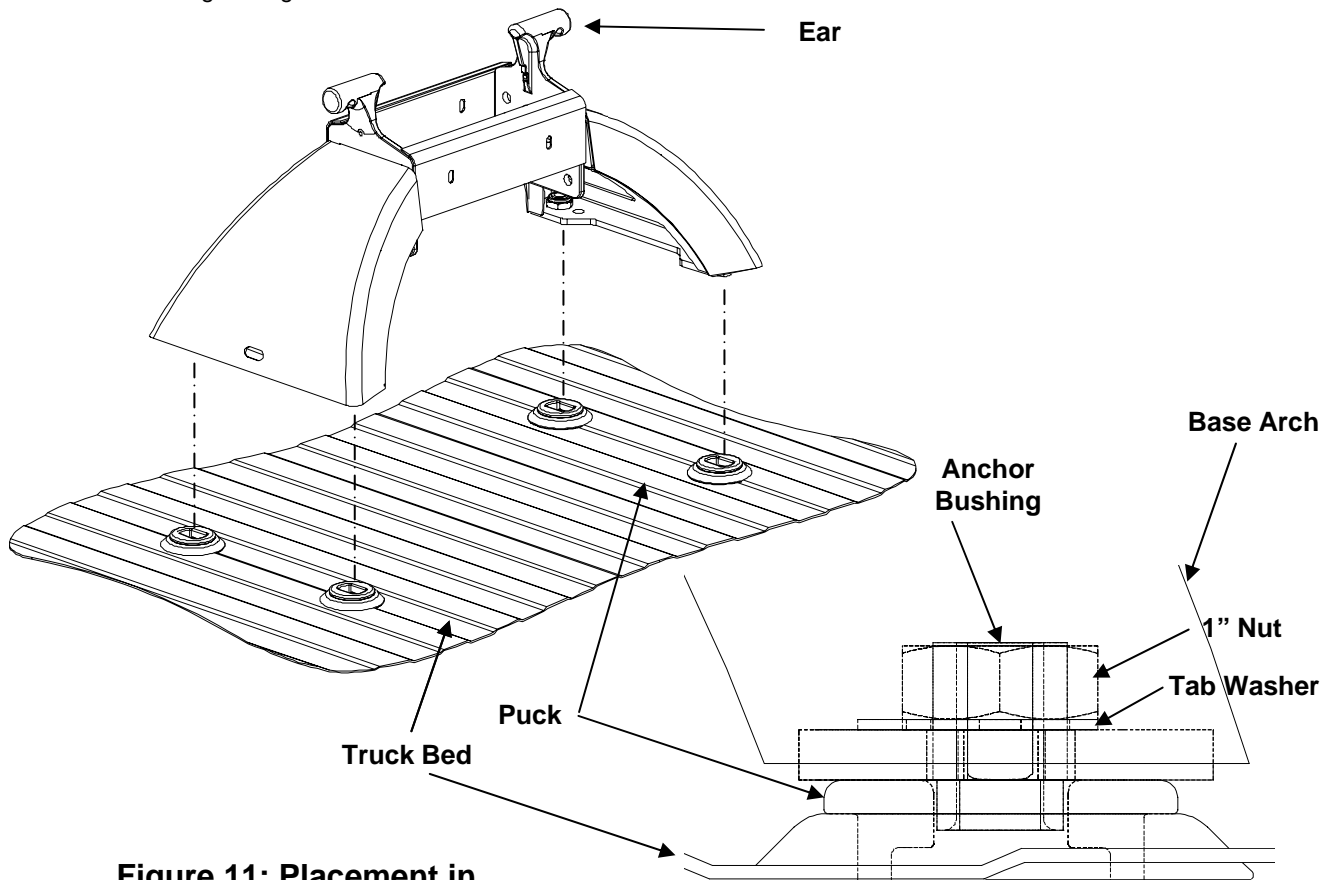


**Forward Offset**

**Rearward Offset**

**Figure 10: King Pin Offset Position Options**

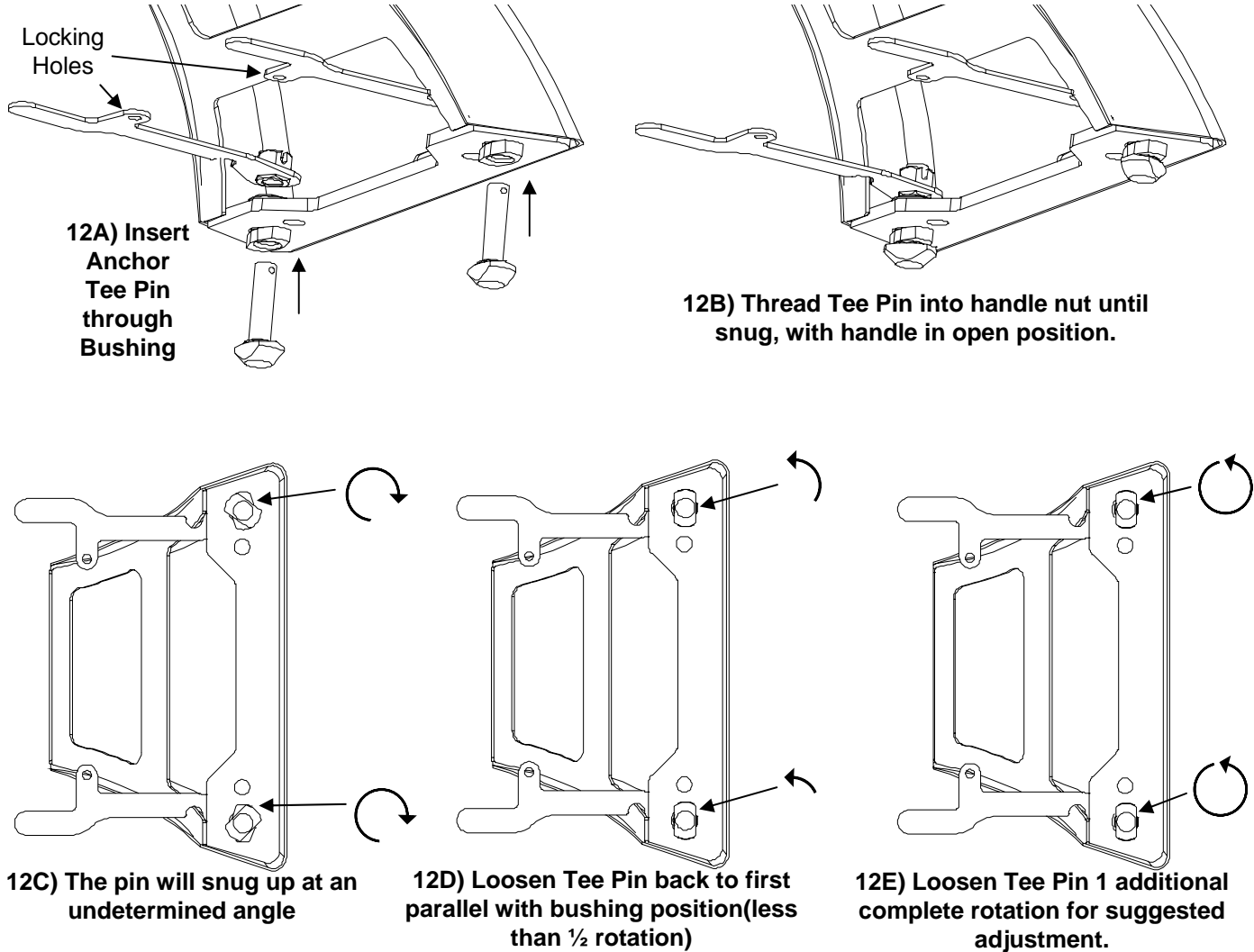
3. Place assembly into mounting pucks which are installed in truck (see *Signature Series* Mounting Kit Instructions) (see Figure 11). Be sure that base arches are contacting all pucks with bushings slid into puck slots.
4. Tighten 5/8 bolts in center section to 170 ft.lbs. using 15/16 socket. Snug tight (no vertical play in anchor bushing assembly) all four 1" jam nuts inside base arches using a 1-1/2" box end wrench, then tighten each jam nut another 1/4 turn for proper torque requirement. Note that the unit is not secured down and should be held while tightening hardware.



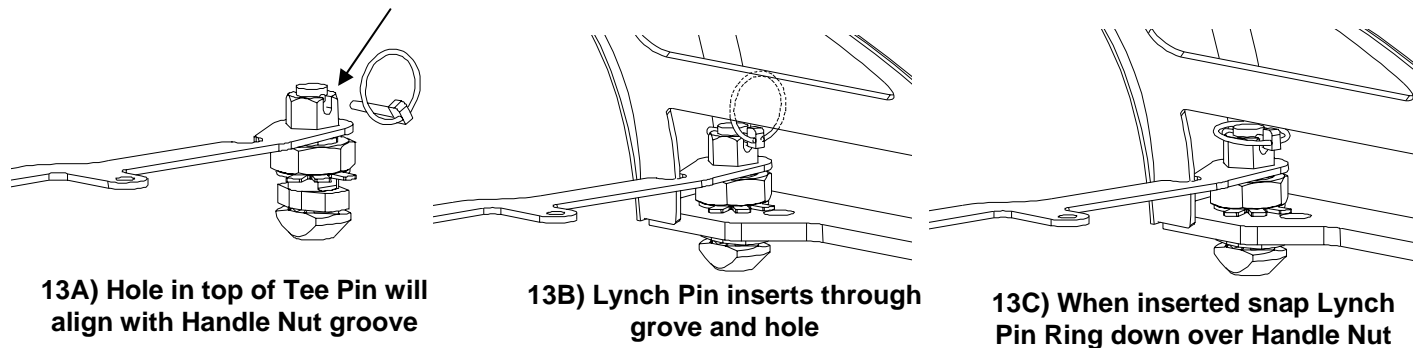
**Figure 11: Placement in Mounting Kit / Truck Bed**

**Base Arch contacts puck and Bushing fits inside**

5. Lift unit out of pucks. There should be minimal resistance. If there is some resistance, or you can not drop the unit back into the pucks, the unit should be adjusted; loosen 1" nuts and Center Section bolts and repeat Steps 3 & 4.
6. Insert anchor tee pin through bushing from bottom of base arch and thread into appropriate handle(see Figures 12A and 12B). (With notch in nut facing up and handle pointing toward you the locking hole is to the right for the left handle and to the left for the right handle.) Keeping the handle in the unlocked position thread the anchor tee pin into handle nut until there is metal to metal contact with the bushing. Back tee pin off until parallel with bushing(less than 1/2 rotation), then loosen 1 more full rotation for nominal clearance adjustment(see figures 12C,12D, and 12E). At this point the slot in the handle nut and the hole in the tee pin should be aligned and the lynch pin needs to be inserted and closed(see Figure 13).



**Figure 12 : Anchor Tee Pin and Handle Orientation(all shown in unlocked position)**



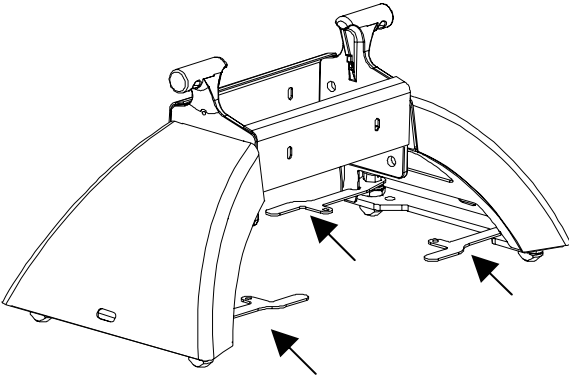
**Figure 13 : Inserting Lynch Pin**

**⚠ WARNING:**  
**Failure to properly install handles could result in tow vehicle damage or truck and trailer separation.**

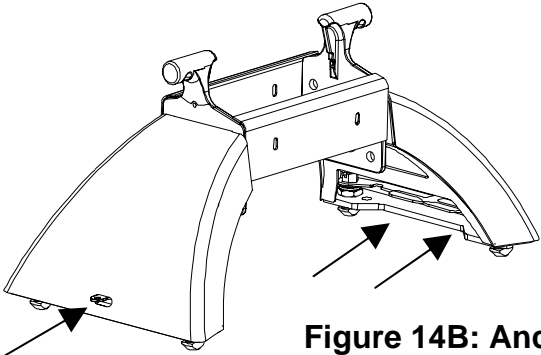
- 7. Replace unit into pucks with all handles in unlocked position(see Figures 14A and 14B). Rotate handles into locked position. It is normal for some of the handles to have very little or no resistance; while others have a moderate amount of resistance when locking. Should a handle not be able to be locked by hand it needs to be adjusted, see Note D

NOTE D: To adjust handle tension when locking first remove hitch from pucks. Next, while keeping the handle to tee pin orientation, remove the lynch pin. Rotate the tee pin counterclockwise ½ rotation, and replace lynch pin. Conversely, if there is too much slop in the attachments when locked, the clearance can be removed by rotating the tee pin clockwise ½ rotation, and replacing the lynch pin.

- 8. Remove hitch assembly and lube(lithium grease) tee pins in bushings, replace unit in pucks.
- 9. Lock handles through arches on both sides and place lynch pins through overlapping handle holes (see Figure 15).



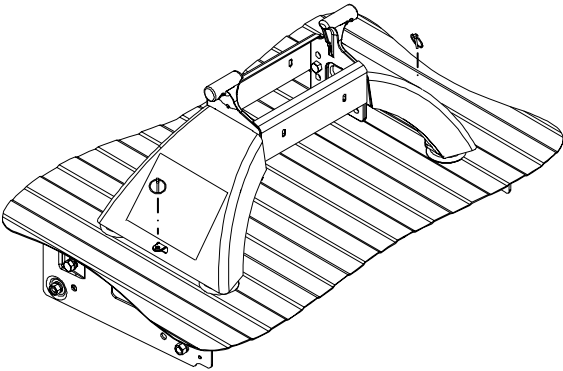
**Figure 14A: Anchor Handles in Unlocked Position**



**Figure 14B: Anchor Handles in Locked Position(overlapped)**

**Locking Hole Tabs in Handles overlap and Protrude through Base Arch**

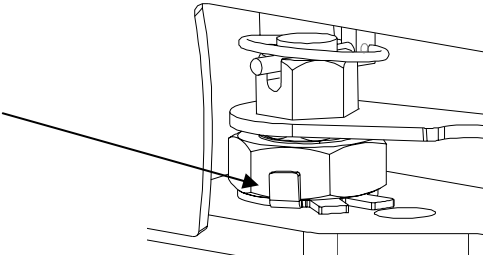
**Figure 15: Pinning Anchor Handles**



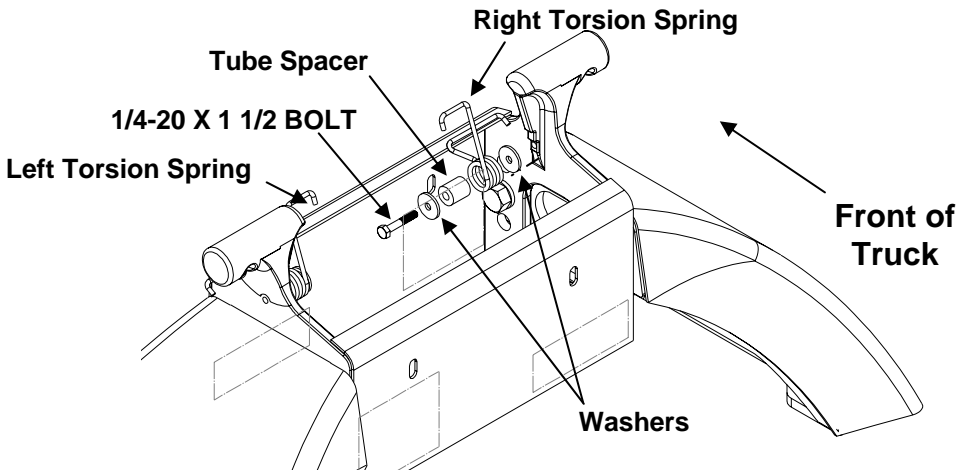
- 10. Bend one tab (that best aligns with flats of nut) up against flat of nut on each of four anchor attachments. This is to ensure that the nuts do not loosen over time.

**Bend up any one tab that aligns with a flat of the nut**

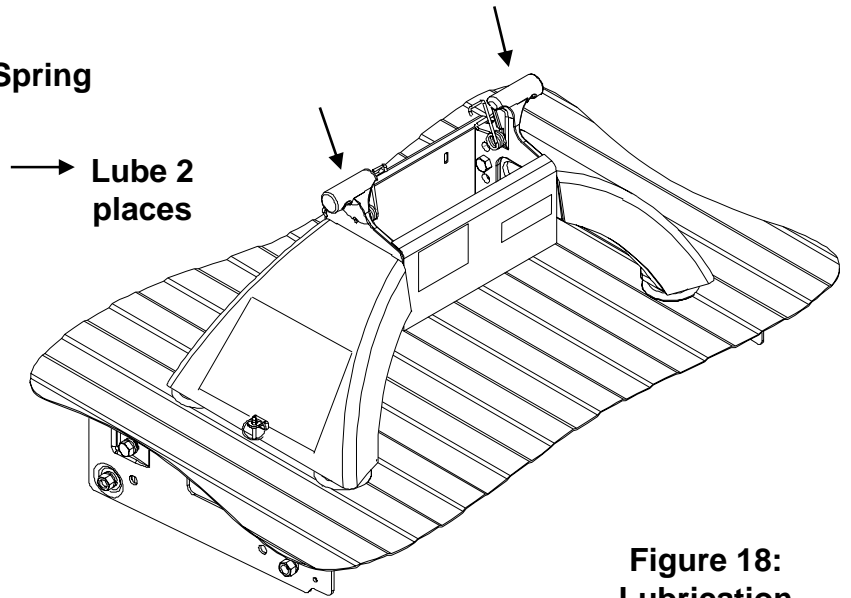
**Figure 16: Bending Up Tab to Flat of Nut**



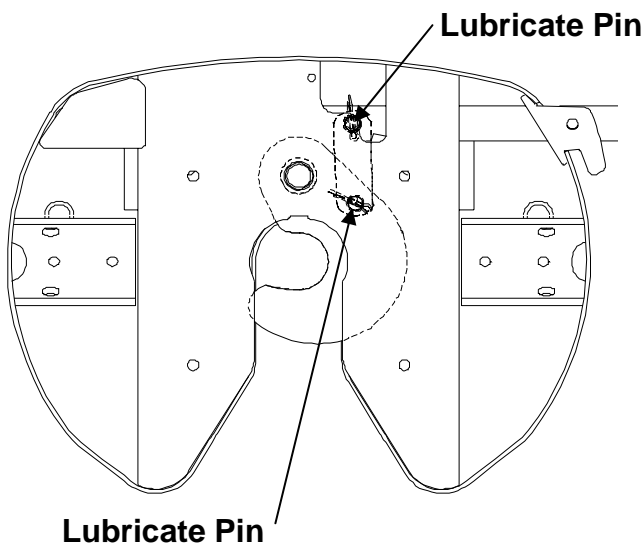
11. Left hand and Right hand torsion springs need to be added to center section so that the coil is facing the rear of the truck and wide hook sits over casting as shown in **Figure 17**. Tighten 1/4-20 X 1 1/2 BOLT with 7/16 socket to 8 ft.lbs.
12. Lube center section as shown in **Figure 18** with lithium grease.
13. Lube pins (2) shown in **Figure 19** prior to installation/operation.



**Figure 17: Torsion Spring Assembly**

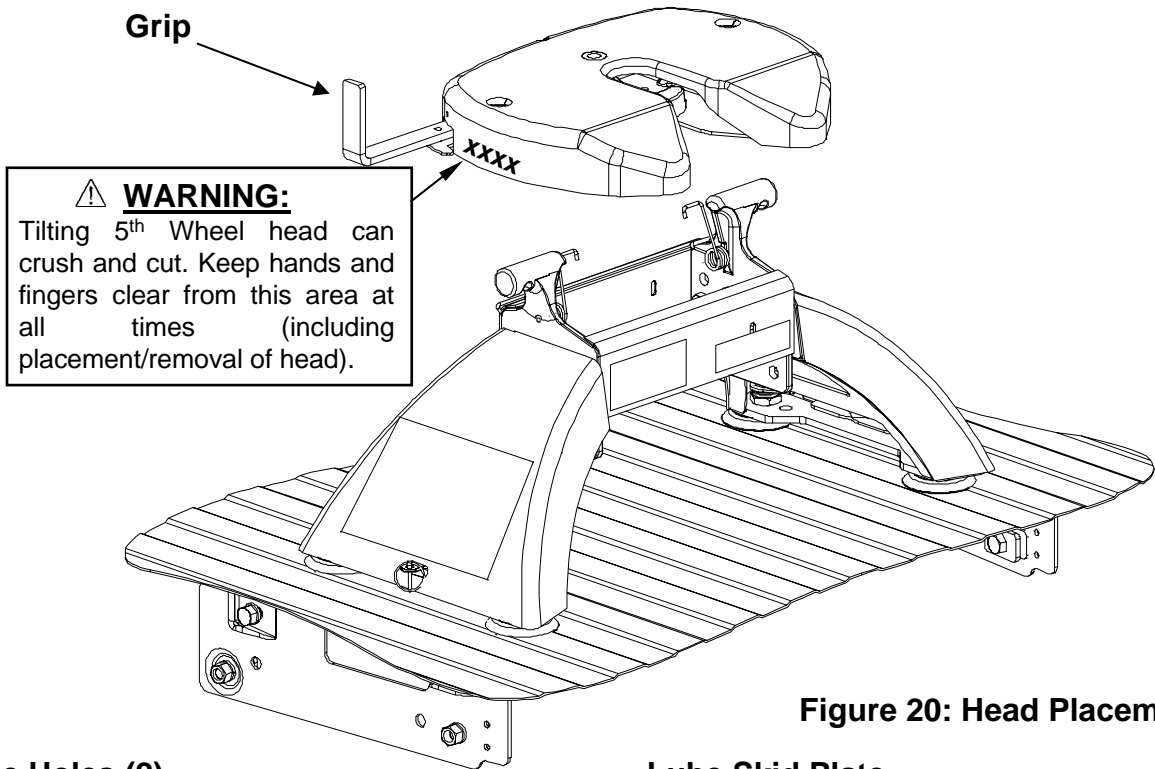


**Figure 18: Lubrication Points**

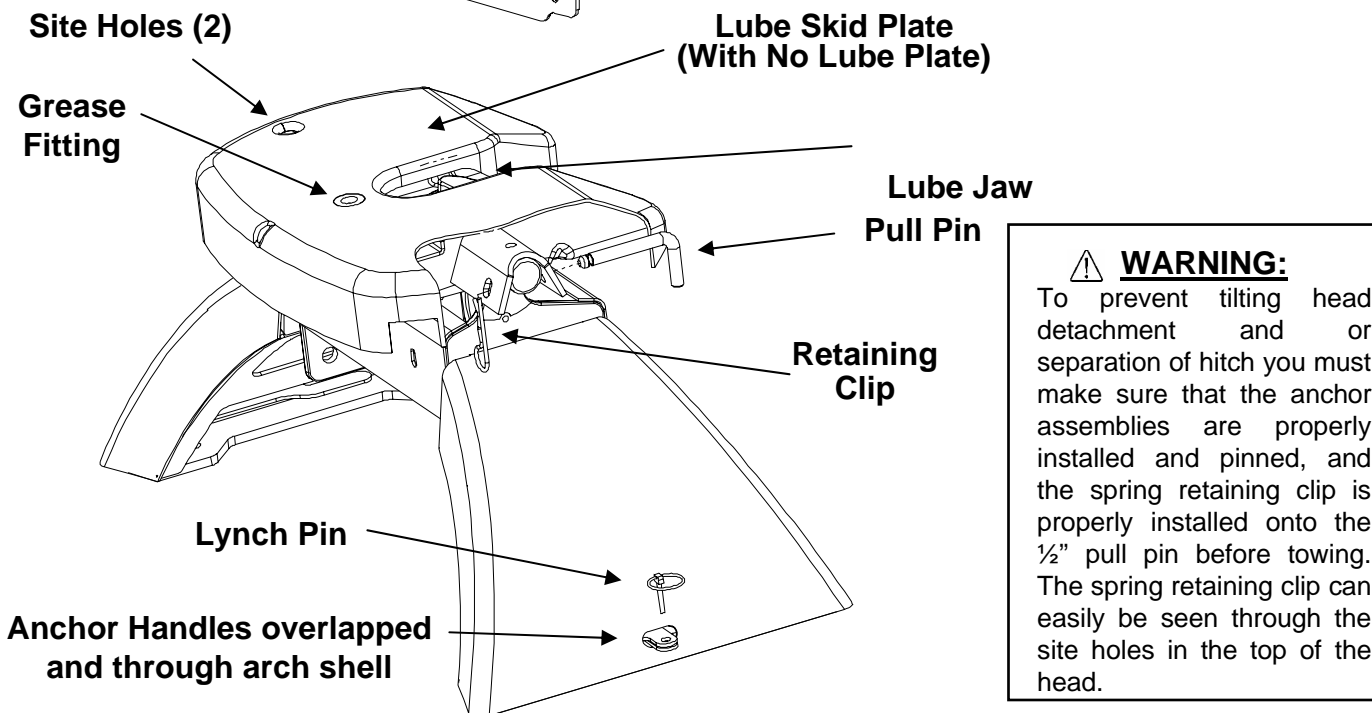


**Lubricate Pin**  
**(Access through jaw opening)**  
**Figure 19: Pin/Lube Points (Bottom View)**

14. Place and pin head onto center section(see Figures 20 & 21). Keep hands clear of ear placement while placing/ removing head onto/off of hitch base as noted on head labels. Head will tilt rearward with proper torsion spring installation(Step 10).
15. Slide handle grip over handle (using liquid soap as a lubricant will ease installation).
16. Lube jaw and skid plate(If no lube plate is being used) with automotive type chassis grease(see Figure 21). The jaw pin comes greased from the factory. To insure smooth jaw operation grease should be added every 6 months to grease fitting on top of head(see Figure 21).



**Figure 20: Head Placement**



**Figure 21 : Pin and Clip (Skid Plate cut away view)**

# NOTES

## SEVEN YEAR LIMITED WARRANTY

### **Fifth Wheel Hitches**

**Cequent Towing Products** warrants the *Signature Series* 5th Wheel Hitch from date of purchase against defects in material and workmanship under normal use and service, ordinary wear and tear excepted, for 7 years of ownership to the original consumer purchaser when a **Cequent Towing Products** mounting kit is used.

**Cequent Towing Products** will replace FREE OF CHARGE any part which proves defective in material or workmanship when presented to any **Cequent Towing Products** dealer, **Cequent Towing Products** Warehouse or returned to factory. TRANSPORTATION CHARGES PREPAID, at the address below. THIS WARRANTY IS LIMITED TO DEFECTIVE PARTS REPLACEMENT ONLY. LABOR CHARGES AND/OR DAMAGE INCURRED IN INSTALLATION OR REPLACEMENT AS WELL AS INCIDENTAL AND CONSEQUENTIAL DAMAGES CONNECTED THEREWITH ARE EXCLUDED.

Some states do not allow the exclusion or limitation of incidental or consequential damages, so the above limitation or exclusion may not apply to you.

Any damage to the 5th Wheel Hitch as a result of misuse, abuse, neglect, accident, improper installation, or any use violative of instructions furnished by us, WILL VOID THE WARRANTY.

This warranty gives you specific legal rights, and you may also have other rights which vary from state to state. In the event of a problem with warranty service or performance, you may be able to go to a small claims court, or a federal district court.

Cequent Towing Products, Inc.  
2602 College Avenue  
Goshen, IN 46528